



## IoT and E-Glove Nurse Calling System

**VARSHA M<sup>1</sup>, RAKSHITHA P<sup>2</sup>, VIVEDHA R<sup>3</sup>, YOGASRI S<sup>4</sup>, RADHIKA D<sup>5</sup>**

<sup>1,2,3,4</sup>Department of Computer Science, Vivekanandha College of Engineering for Women/ Afflicted to Anna University, Tamilnadu, India.

<sup>5</sup>Assistant. Prof., Department of Computer Science, Vivekanandha College of Engineering for Women/ Afflicted to Anna University, Tamilnadu, India.

### How to cite this paper:

VARSHA M<sup>1</sup>, RAKSHITHA P<sup>2</sup>, VIVEDHA R<sup>3</sup>,  
YOGASRI S<sup>4</sup>, RADHIKA D<sup>5</sup>, "IoT and E-Glove Nurse  
Calling System", IJIRE-V3I03-391-395.

Copyright © 2022 by author(s) and 5<sup>th</sup> Dimension  
Research Publication.

This work is licensed under the Creative Commons  
Attribution International License (CC BY 4.0).

<http://creativecommons.org/licenses/by/4.0/>

**Abstract:** Every patients in a hospital need a immediate emergency in a unpredictable time, Traditionally every hospital allocated a number of nurses to number of patients. But hardly it's impossible to monitor every individual patients when counts increases or when shortage of physicians and nurses. So, we bring an idea namely Wireless nurse call system (WNCS) to detect patient in danger or need an immediate treatment or aid. Which helps in preventing and treating them in quick manner. This project mainly aims in designing a system which is capable of helping patients to call in case of emergency through hand gestures. This project works with hand glove which enable those gesture which we mentioned previously. In this system, we use Arduino Micro-controller, and transmitting device at patient end and receiver and LCD monitoring display at Nurse end through which if patient meets any ill, it send signals to nurse end receiver and display patient in ill. A wireless nurse call system is a new advanced technology, this will helps patients to use them in an easy and hassle freeway, receiving its medical assistance quickly. Since it does not need the usage of any wires like old versions of nurse call systems, it becomes very simple for hospital staff to deploy and use it within minutes.

**Keywords:** WNCS, Arduino-Microcontroller, transmitting device, LCD display

### I. INTRODUCTION

There is a huge demand of nursing staff across the globally. The condition is worse than ever among developed countries. As per nursing council of India (NCI), there's only 45 percentage of registered nursing staffs are actively working. This has result in the decrease in patient to nurse ratio. The suggested ratios are 1:1, 1:3 and 1:6 in the critical care unit, intermediate care unit and general ward respectively. Since the duty of the nursing staff occur in 3 shifts, the shortage of nursing staff looks grimmer. As per the recent report in many public hospital the nurse patient ratio hovers around 1:60 during evening and night shifts. The stress and work pressure have been reported to be major deterrent for the nurses to join nursing staff the afore mentioned factors hamper the patient care to great extend. Keeping this in mind this project has been developed a low cost nurse calling system which can help reducing the work pressure of nurse.

A wireless nurse call system is a new advanced technology, this will helps patients to use them in an easy and hassle free way, receiving its medical assistance quickly. Since it does not need the usage of any wires like old versions of nurse call systems, it becomes very simple for hospital staff to deploy and use it within minutes. Developments in nurse call system technologies allows them to be integrated with smart digital devices. That enables nurses and cares to communicate instantly with each other and patients and residents, as well as potentially providing more rapid access to clinical data.

### II. RELATED WORK

In this topic, we provides a summary of previous case research as well as experimental learnings related to the similar work. The previous work had done by Rabiattul Ainn Binti Mohamed and their aim of the project is to create a system that helps patients perform daily tasks such as lifting, gripping, and grasping. This glove is made up of five flex sensors that are located on all of the fingers. Then, utilizing Arduino Super, these sensors may be used as an input to regulate the movement of fingertips. Arduino serves as a connection between the flex sensors and the LED and LCD indicators. Debeshi Dutta, Biswajeet Champaty and his team developed a flexible and wearable attender calling Fysol Iba Abbas Dept. of Electrical and Electronic Engineering, City University, Dhaka 1216, Bangladesh Department of Theoretical Physics, University of Dhaka, Dhaka 1000, Bangladesh Graduate School of Science, Tokyo Metropolitan University, 1-1 Minami-Osawa, Hachioji 192-0397, Japan [fysolibnaabbas@gmail.com](mailto:fysolibnaabbas@gmail.com) Md. Saniat Rahman Zishan Dept. of Electrical and Electronic Engineering American International University Bangladesh Dhaka 1229, Bangladesh [saniat@aiub.edu](mailto:saniat@aiub.edu) device based on hand finger movement. The device is rendered by placing a flex sensor on a hand glove base that corresponds to the location of the device's "forefinger" [6]. Vimalkumar A. Parmar and Kartik D. Kothari developed a method for calibrating flex sensors to increase sensitivity, accuracy, and linearity to more precisely calculate joint angles. A schematic model of different bend angles was used to verify the radial accuracy of flex

## IoT and E-Glove Nurse Calling System

sensors to successfully calibrate the sensors. The obtained data would be graphically and electronically reviewed. Tejaswini A. Futane, Sneha S. Khode, and their team collaborated on a project with the main goal of detecting finger location and giving commands to the doctor. It involves a glove with flex sensors and an electrical conditioning circuit attached to it .

### III. PROPOSED MODEL

Our proposed system aims to break all the barriers when it comes to communication and monitoring patients and provide hassle free support to patients and reliable health care. Using RF technology we bring a solution to this problem happening around hospitals, it gives appropriate monitoring and displaying conditions of patients assistance needed. The proposed system is divided into three major modules: patient unit, next is nurse monitoring unit and Software application unit. Arduino UNO is the basic module. It is very basic for beginners to learn and implement for students' projects. A power module operates from 1.9 V to 3.6 V, but it tolerates up to 5V. So we can connect Arduino up to 5V. The Nursing Room receives the signal from the patient's room and shows the patient room number. It also delivers to a web module.

### IV. SYSTEM REQUIREMENTS

#### HARDWARE REQUIREMENTS :

- Arduino Uno (Atmega328P)
- Buzzer
- MEMS Sensor
- Hitachi HD44780 LCD controller
- RF Transmitter Module (HT12E)
- E-Glove.

#### SOFTWARE REQUIREMENTS:

- Arduino IDE
- Embedded C
- Proteus
- Web module.



#### **Arduino UNO:**

1. The Arduino Uno is a microcontroller board based on the ATmega328P. It has 14 digital input/output pins.
3. It can be used by connecting it to a computer with a USB cable or power it with a AC-to-DC adapter.

#### **Buzzer:**



Buzzer is an integrated component of electronic transducers, DC power supply, which is used in computers, printers, alarms, electronic toys, automotive electronic equipment, telephones, timers and so on.... Buzzer 5V. Defined power can be directly plugged into a continuous sound, this part is a dedicated sensor expansion module and the board in combination, can provide a simple circuit design, to plug and play.

**RF transmitter module:**

An RF transmitter module is a mini PCB set which has a efficiency of transmitting a RF wave and modulating that wave to carry information. Transmitter modules are generally implemented a part of a micro controller which will provide data to the module which can be transmitted. RF transmitters are subjected to regulatory requirements which gives the maximum allowable transmitter power output, harmonics, and band edge requirements.

**V. WORKING METHODOLOGY**

**Patient room unit:** In this unit, patient who in danger or in need of medical assistance can use gesture movement if they are really sick with another reason can notify nurse and other receiver by giving appropriate gesture can sense by devices and alert nurse by sending message of patient name and room number through RF transmitter and Nurse can urge if it is emergency.

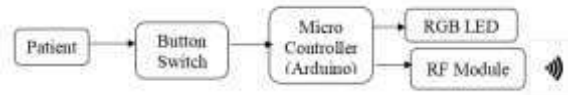

**Nurse Monitoring unit:**

In this nurse monitoring unit, the patient data such as room number and patient name can be display in LCD monitoring unit and this is the message which notifies the staff that patient in emergency of need in medical assistance.

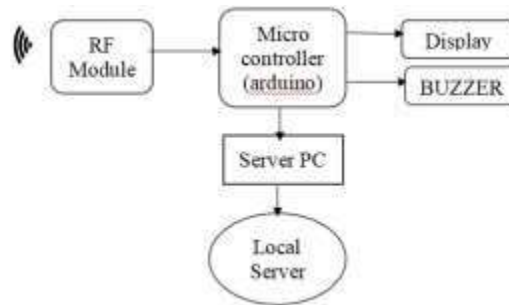

**Database unit:**

The information which shared to Nurse monitoring unit can be shared to Database and store all the database. This can be used only by administration and Duty Doctors of particular Institution. A login portal has been created where the concerned person can login and retain data or review it.

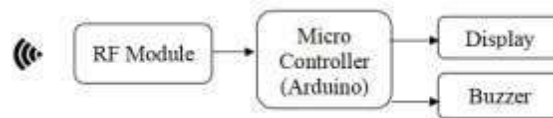

**VI. EXPERIMENTAL RESULT**

**Patient Room Unit:**

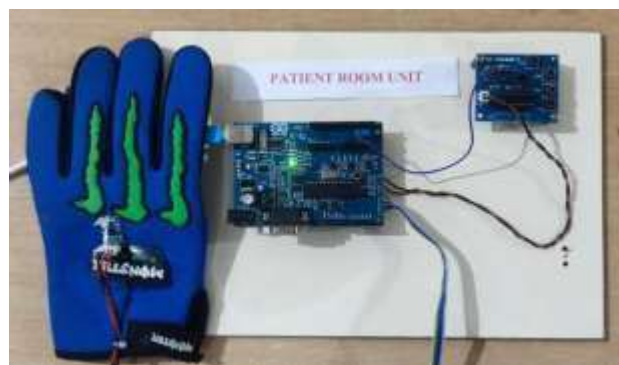

**Nurse Monitoring Station:**

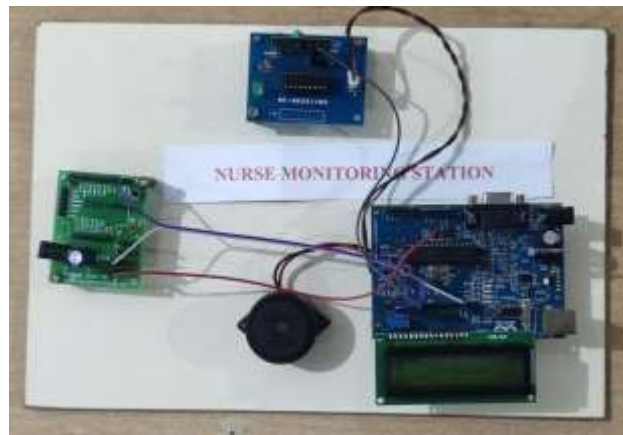

**Database Unit:**



**Database unit:**

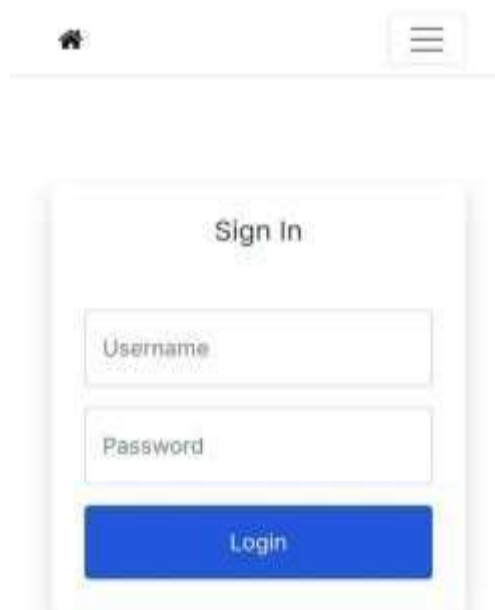

#1	Patient ID	Patient Name	Disease	Nurse ID	Date & Time
1	401C	KUDHALI	ADIPYKKA	1E	2022-05-28 21:19:34
2	402D	KUPPUSAMP	HEART SURGERY	1E	2022-05-28 21:19:35
3	402D	APPALAM	HEART SURGERY	4E	2022-05-28 21:19:36
4	401C	KUDHALI	ADIPYKKA	1E	2022-05-28 21:19:38
5	402D	KUPPUSAMP	HEART SURGERY	1E	2022-05-28 21:19:39
6	401C	KUDHALI	ADIPYKKA	1E	2022-05-28 22:04:18
7	400D	KUPPUSAMP	HEART SURGERY	1E	2022-05-28 22:23:48
8	402D	HEART SURGERY	ROOM NO.10	4E	2022-05-28 22:22:19
9	402D	HEART SURGERY	ROOM NO.10	4E	2022-05-28 22:07:07
10	402D	HEART SURGERY	ROOM NO.10	4E	2022-05-28 22:02:34

## VII.CONCLUSION

We use Wireless system to transfer and receive database avoid high usage of wires for transmission,also cause minimal negative impact on environment.Wireless system is cost efficient and transfer high speed data.It is easier to install.It is suitable to satisfy the need of every hospital and adapted to work with any individual’s budget.It helps in increasing the efficiency of overall staffs and improves the quality of health-care technologies.

Already we have our mini demo prototype which performs well. But in case of product concerns,we undergo performing in our project with more focus to reduce the cost of development and durability.We hope,very soon we hit market with affordable to every hospitals.

## Reference

1. pp. 169-176,2010 Tika Miller, “Nurse Call Systems: Impact on Nursing Performance,” *Journal of Nursing Care Quality*, Vol.11, Issue 3, Feb. 1997,pp. 36-43.
2. *Examination of Wireless Technology To Improve Nurse Communication, Response Time to Bed Alarms, and Patient Safety.*
3. Ambar, R. B., Poad, H. B. M., Ali, A. M. B. M., Ahmad, M. S. B., & Jamil, M. M. B. A. (2012, February). *Multi-sensor arm rehabilitation monitoring device. In 2012 International Conference on Biomedical Engineering (ICoBE) (pp. 424-429). IEEE.*
4. [4]F M S Nursuwars and A Rahmatulloh “RFID for nurse activity monitoring in the hospital’s nurse call system with Internet of Thing (IoT) concept “IOP Conf. Ser.: Mater. Sci. Eng. 550 012025, 2019
5. Shashidhar, R., Abhilash, S., Sahana, V., Alok, N. A., & Roopa, M. (2020). *Iot cloud: In health monitoring system. International Journal of Scientific and Technology Research*, 9(1), 227.
6. Antoni Morey, Pasqual,” *Composition of New Feature into Wireless Nurse Call System” Master of Science in Communication Technology, Norwegian University of Science and Technology, Jan 2011.*
7. Mohamed Hesham Aref1, Ahmad Aly El-Shinnawi2 , Amr A. Sharawi3 “*Wireless Nurse Call System in Medical Institutions” American Journal of Biomedical Research*, Vol. 6, No. 2, 40-45,2018.
8. Ravi Pratap Singh, Mohd Javaid , Abid Haleem , Rajiv Suman “*Internet Of Things (Iot) Applications To Fight Against COVID-19 Pandemic “Diabetes & Metabolic Syndrome: Clinical Research & Reviews 14 (2020) 521e524, April 2020.*
9. *Irjmets.com*, 2021. [Online]. Available: [https://irjmets.com/rootaccess/fo\\_rms/uploads/IRJMETS888370.pdf](https://irjmets.com/rootaccess/fo_rms/uploads/IRJMETS888370.pdf). [Accessed: 23- Jun-2021].
10. Mohamed, Rabiattull Ainn Binti. “*Design of Finger Bending Measurement System.” Journal of Applied Engineering & Technology (JAET) 2.2 (2018): 31-43.*
11. [11]L. McGillis Hall, C. Pedersen, and L. Fairley, “*Losing the moment: Understanding interruptions to nurse’s work*”, *JONA*, 40.
12. [12]“*ATMEL Wireless Production Test Reference*”; 42253A–WIRELESS–03/2014, issued in 2014. V. “*NPpocket Nursing” Book, 1st edition, issued in 2017; ISBN-13: 978-1943991693.*