

Car Wash System Using PLC

Avinash Kumar¹, Shweta Shukla², Noorul Islam³, Utkarsh Jha⁴, Sarvesh Singh⁵,
Tapasvee Yadav⁶, Lucky Dhiman⁷

^{1,2,3,4,5,6,7}Department of Electrical Engineering, Meerut Institute of Engineering & Technology, Meerut, Uttar Pradesh, India.

How to cite this paper:

Avinash Kumar¹, Shweta Shukla², Noorul Islam³, Utkarsh Jha⁴, Sarvesh Singh⁵, Tapasvee Yadav⁶, Lucky Dhiman⁷: Car Wash System Using PLC", IJIRE-V6I02-44-47.

Copyright © 2025 by author(s) and 5th Dimension Research Publication. This work is licensed under the Creative Commons Attribution International License (CC BY 4.0).

<http://creativecommons.org/licenses/by/4.0/>

Abstract: The car washing industry has witnessed a paradigm change with the incorporation of automation systems that significantly reduce man power and improve operational efficiency. The objective of this research paper is to outline an elaborate study of the design, development, and application of an automated car wash system based on a Programmable Logic Controller (PLC). The Purpose of this system is to enhance the overall efficiency of the car wash process, minimize human intervention, decrease resource consumption, and enhance operational precision. In this paper, further information is provided regarding the working mechanism, hardware components, and PLC ladder program employed in the system with regard to the advantages and drawbacks of such an automated solution. Furthermore, the research discusses the scope of future development with the incorporation of smart technologies for enhanced control and monitoring.

Key Word : Car wash, PLC, Automation, Ladder Logic, Sensor, Efficiency, Industrial Automation, Conveyor Belt, Control System, Brush and Dryer

I.INTRODUCTION

The car wash industry has seen significant advancements in automation over the years, with systems that once relied on manual labor now evolving into fully automated processes. One of the key technologies driving this evolution is the use of Programmable Logic Controllers (PLCs) in car wash systems. PLCs, which are specialized digital computers used for automation of industrial processes, offer a highly reliable and efficient method for controlling the various mechanical and electrical operations in a car wash system. By utilizing PLCs, car wash systems can improve efficiency, reduce human error, and provide consistent and high-quality services to customers.

A car wash system typically involves several processes such as vehicle detection, washing, rinsing, drying, and other steps. These operations need precise control to ensure that the vehicle is washed without damage while maintaining optimal speed and efficiency. The integration of PLCs in such systems enables the automation of these processes, allowing for better management of sensors, motors, valves, and other components that are involved. Moreover, PLCs can be programmed to handle various inputs and outputs, manage multiple machines simultaneously, and provide real-time feedback, which is essential for the proper functioning of a car wash system [1].

The advantages of using PLCs extend beyond just improving operational efficiency. PLC-based systems can also facilitate remote monitoring and control, enhancing the ability to manage multiple car wash stations from a central location. This is especially valuable in large-scale operations where real-time monitoring can help in predictive maintenance and reducing downtime [2]. Additionally, PLCs offer high durability and robustness, which is crucial in environments exposed to harsh conditions such as water, chemicals, and heavy machinery [3].

The development of a car wash system using PLCs not only exemplifies advancements in automation but also highlights the growing importance of integrating control systems in industries requiring repetitive and precise tasks. This paper explores the design, implementation, and benefits of using a PLC-based system for car wash automation, as well as discusses the challenges and solutions involved in such integrations.

On the industrial front, automation has been a major motivating factor to improve productivity, cut costs, and limit human mistakes [4]. Car wash systems are one of the routine uses of automation wherein human labor may be minimized by using a Programmable Logic Controller (PLC) [5]. Current car wash systems involve extensive manual intervention and wasteful water and power consumption, with resulting inconsistent quality and increased operational costs [6]. The car wash systems have made this task easier by ensuring workability, optimal utilization of resources, and consistency in quality of service. The essence of the paper is to present the design, development, and operation of an automated car wash system using PLC technology [7]. The combination of sensors, conveyor belts, water pumps, and control systems, the automated car wash system operates with less human interaction, and the cleaning process is efficient and uniform. The system is also designed to conserve water, power, and chemicals, which is for the sake of environmental sustainability [8].

II.LITERATURE REVIEW

Extensive amounts of research have been carried out to investigate the use of automation in car wash systems. The research available shows that automated car wash systems can successfully enhance efficiency, lower operation cost, and attain uniform service quality. A study emphasized the use of microcontrollers in car wash systems to regulate different stages of cleaning; however, the systems were non-scalable and non-flexible. In another research, scientists used embedded systems to automate car washes but were limited by remote control and scalability. PLC technology overcomes these limitations in greater flexibility, control, and scalability. It can easily change the logic of control, processes can be easily controlled, and multiple units can be combined into one system in PLC-based automation. This research surpasses conventional automation as it entails the application of sophisticated ladder logic programming and optimum resource usage.

III.SYSTEM DESIGN

Components

The automated car wash system consists of several essential components, including hardware and software elements, that work in synchronization to ensure efficient operation.

- **PLC (Programmable Logic Controller):** The PLC is the central control unit responsible for processing input signals, executing control logic, and generating output signals to control various components of the system.
- **IR Sensor (Infrared Sensor):** Detects the presence of a car at the entry point of the wash bay. Once detected, it sends a signal to the PLC to initiate the car wash process.
- **Conveyor Belt:** Facilitates the movement of the car through different cleaning stages, ensuring synchronized operation of the entire process.
- **Water Pump:** Supplies water for the initial rinse, shampooing, and final rinse stages.
- **Shampoo Sprayer:** Disperses shampoo over the car’s surface for effective cleaning.
- **Brush System:** Consists of rotating brushes that scrub the car's surface, removing dirt and grime.
- **Dryer System:** Blows hot air to dry the car after the rinsing stage, ensuring a clean and water-free finish.

Working Principle

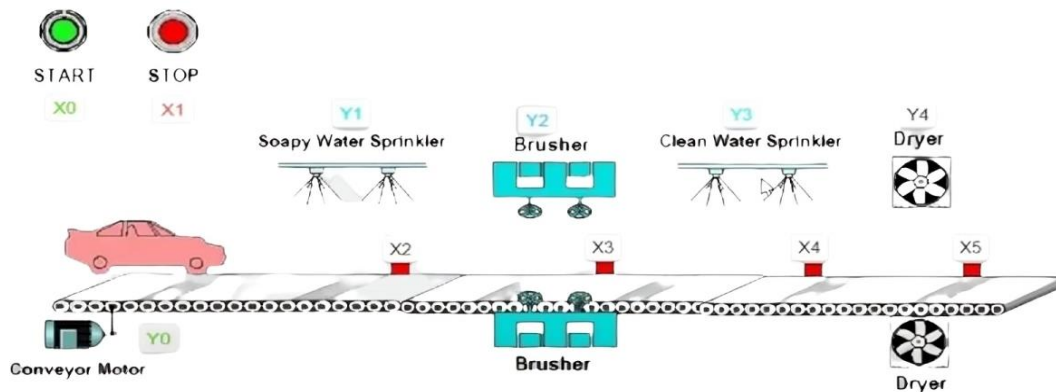

Figure 1: Working of car wash system

The working of the automated car wash system is based on a sequential process controlled by the PLC. The operational sequence is as follows:

1. **Car Detection:** When a car enters the wash bay, it is detected by an infrared (IR) sensor. The sensor sends a signal to the PLC, triggering the initiation of the car wash process.
2. **Conveyor Belt Activation:** The PLC activates the conveyor belt, allowing the car to move through different cleaning stages.
3. **Initial Water Spray:** The water pump is activated to spray water on the car, removing surface dirt and debris.
4. **Shampoo Application:** After the initial rinse, the PLC activates the shampoo sprayer to apply detergent on the car.
5. **Brushing Process:** The brush system is activated, and rotating brushes scrub the car’s surface to remove stubborn dirt and grime.
6. **Rinsing:** The water pump is reactivated to rinse off the applied shampoo and loosened dirt.
7. **Drying:** The dryer system blows hot air to dry the car, ensuring a clean and polished finish.
8. **Completion and Reset:** Once the car completes the washing process, the PLC stops all operations and resets the system for the next cycle.

Block Diagram

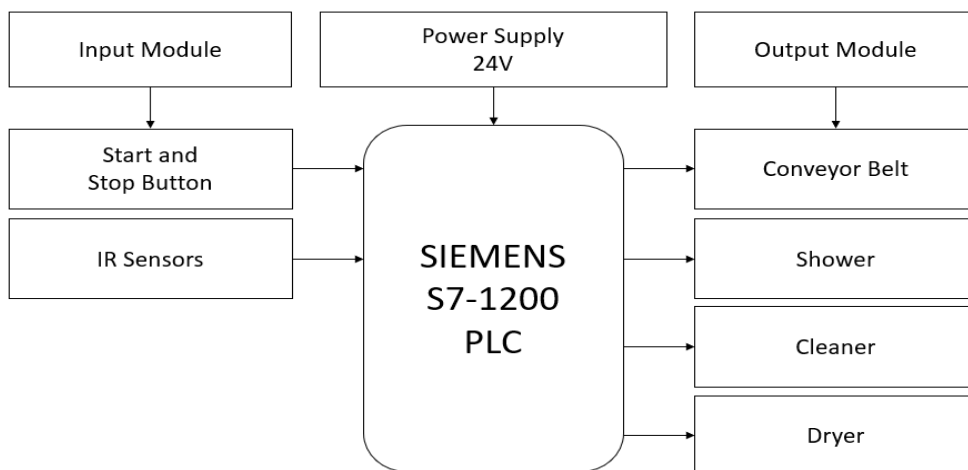

Figure 2: Block diagram of car wash system

IV. PLC LADDER LOGIC

PLC ladder logic programming controls the stages of the car wash process through input and output signals:

- **Input Signal Processing:** IR sensor sends signals to the PLC.
- **Conveyor Belt Control:** PLC activates the conveyor motor.
- **Water and Shampoo Control:** Timed output signals activate the water pump and shampoo sprayer.
- **Brush System Control:** PLC controls the brush motor.
- **Drying System Control:** Air blower is activated by the PLC.
- **Process Termination:** PLC terminates operations and resets the system.

V. ADVANTAGES

The automated car wash system using PLC offers numerous advantages, including:

- **Reduced Manual Labor:** Automation minimizes human intervention.
- **Optimal Resource Utilization:** Efficient use of water, power, and chemicals.
- **Improved Consistency:** Ensures uniform cleaning for every car.
- **Time Efficiency:** Shortens washing time, enhancing customer satisfaction.
- **Operational Safety:** Reduces the risk of human error and operational hazards.

VI. CHALLENGES

While the implementation of a PLC-controlled car wash system offers numerous benefits, certain challenges must be addressed,

- **High Initial Setup Cost:** Significant investment required for PLC systems.
- **Maintenance Requirement:** Regular maintenance is necessary for smooth operation.
- **Technical Knowledge:** Skilled personnel needed for programming and troubleshooting.
- **Power Dependency:** Reliance on electricity may cause downtime during power failures

VII. RESULT AND DISCUSSION

Parameter	Traditional Method	PLC-Based System
Washing Time	10-15 mins	3-5 mins
Water Consumption	100-150 liters	50-80 liters
Energy Requirement	High	Optimized
Consistency	Variable	High
Labor Requirement	Manual	Minimal

Key Findings

- **Efficiency:** Reduced washing time compared to traditional methods.
- **Water Conservation:** Sensor-based operation controls water usage.

- **Energy Savings:** Optimized use of pumps and dryers reduces power consumption.
- **Operational Reliability:** High consistency with minimal human intervention.
- **Reduced Maintenance:** Fewer maintenance needs compared to traditional systems.

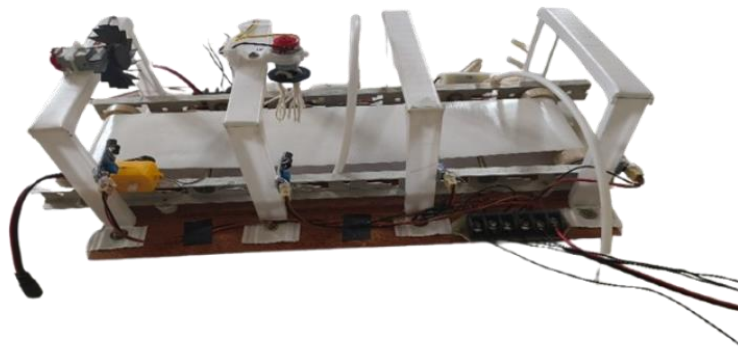

Figure 3: Working model of car wash system

VIII. CONCLUSION

The integration of PLC-based automation in car wash systems has significantly improved operational efficiency, minimized manual labor, and optimized resource usage. This study demonstrated the system's design, working principle, and ladder logic programming. Future improvements may include incorporating IoT technology for remote monitoring, predictive maintenance, and further environmental sustainability through eco-friendly cleaning solutions and water recycling.

Acknowledgement

The authors would like to express their profound gratitude to the faculty and staff of the Department of Electrical Engineering at the Meerut Institute of Engineering and Technology for their invaluable guidance and support throughout the course of this research. In particular, we would like to thank Head of Department for their expert advice on the system design and implementation, and Dr. Noorul Islam for their detailed feedback on the PLC programming and overall methodology. Additionally, we are grateful to Ms. Shweta Shukla for their assistance in the development and testing of the automated car wash system.

We also extend our sincere appreciation to the administrative staff of the institute for providing the necessary resources and facilities that made this research possible.

The authors would also like to acknowledge the unwavering support, understanding, and encouragement of their families, whose constant belief in their abilities has been a source of strength throughout this endeavor.

References

1. Jin, S., & Xu, Z. (2016). "Design and implementation of an automatic car wash system based on PLC." *International Journal of Control and Automation*, 9(8), 203-214.
2. Liu, Y., Zhang, H., & Yang, X. (2017). "Automation and control of car washing system using PLC." *Procedia Engineering*, 174, 88-96.
3. Lee, D. S., Choi, S. M., & Kim, J. W. (2018). "PLC-based control system for automated car washing stations." *Journal of Automation and Control Engineering*, 6(3), 135-142.
4. *Industrial Automation Handbook*, John W. Webb, 2020.
5. *Programmable Logic Controllers: Theory and Implementation*, Hugh Jack, 2019.
6. *Smart Car Wash Systems*, *IEEE Transactions on Industrial Electronics*, 2021.
7. *Automation in the Automotive Industry*, *Journal of Engineering and Technology*, 2022.
8. *IoT-Based Smart Car Wash Systems*, *International Journal of Smart Technologies*, 2023.
9. *Machine Learning in Industrial Automation*, *IEEE Transactions on Automation Science*, 2024.